

1. These specification sheets include materials protected under copyright of Sharp Corporation ("Sharp"). Please handle with great cares and do not reproduce or cause anyone to reproduce them without Sharp's consent.
2. When using this Sharp product, please observe the absolute maximum ratings, other conditions and instructions for use described in the specification sheets, as well as the precautions mentioned below.
Sharp assumes no responsibility for any damages resulting from use of the product which does not comply with absolute maximum ratings, other conditions and instructions for use included in the specification sheets, and the precautions mentioned below.

(Precautions)

- (1) In making catalogue or instruction manual based on the specification sheets, please verify the validity of the catalogue or instruction manuals after assembling Sharp products in customer's products at the responsibility of customer.
- (2) This Sharp product is designed for use in the following application areas ;
 - Computers • OA equipment • Telecommunication equipment (Terminal) • Measuring equipment
 - Tooling machines • Audio visual equipment • Home appliancesIf the use of the Sharp product in the above application areas is for equipment listed in paragraphs (3) or (4), please be sure to observe the precautions given in those respective paragraphs.
- (3) Appropriate measures, such as fail-safe design and redundant design considering the safety design of the overall system and equipment, should be taken to ensure reliability and safety when Sharp product is used for equipment in responsibility of customer which demands high reliability and safety in function and precision, such as ;
 - Transportation control and safety equipment (aircraft, train, automobile etc.)
 - Traffic signals • Gas leakage sensor breakers • Rescue and security equipment
 - Other safety equipment
- (4) Sharp product is designed for consumer goods and controlled as consumer goods in production and quality. Please do not use this product for equipment which require extremely high reliability and safety in function and precision, such as ;
 - Space equipment • Telecommunication equipment (for trunk lines)
 - Nuclear power control equipment • Medical equipment
- (5) Please contact and consult with a Sharp sales representative if there are any question regarding interpretation of the above four paragraphs.

3. Disclaimer

The warranty period for Sharp product is one (1) year after shipment.
During the period, if there are any products problem, Sharp will repair (if applicable), replace or refund.
Except the above, both parties will discuss to cope with the problems.

The failed Sharp product after the above one (1) year period will be coped with by Sharp, provided that both parties shall discuss and determine on sharing responsibility based on the analysis results thereof subject to the above scope of warranty.

The warranty described herein is only for Sharp product itself which are purchased by or delivered to customer.
Damages arising from Sharp product malfunction or failure shall be excepted.

Sharp will not be responsible for the Sharp product due to the malfunction or failures thereof which are caused by:

- (1) storage keep trouble during the inventory in the marketing channel.
- (2) intentional act, negligence or wrong/poor handling.
- (3) equipment which Sharp products are connected to or mounted in.
- (4) disassembling, reforming or changing Sharp products.
- (5) installation problem.
- (6) act of God or other disaster (natural disaster, fire, flood, etc.)
- (7) external factors (abnormal voltage, abnormal electromagnetic wave, fire, etc.)
- (8) special environment (factory, coastal areas, hot spring area, etc.)
- (9) phenomenon which cannot be foreseen based on the practical technologies at the time of shipment.
- (10) the factors not included in the product specification sheet.

4. Please contact and consult with a Sharp sales representative for any questions about Sharp product.

1. Application

This technical sheets applies to the outline and characteristics of time of flight sensor

Model No. GP2AP02VT00F

2. Outline Refer to the drawing page 7.
3. Ratings and characteristics Refer to the attached sheet, Page 8 to 9.
4. Reliability Refer to the attached sheet, Page 10.
5. Outgoing inspection Refer to the attached sheet, Page 11.
6. Supplement
 - 1) This product is built-in SPAD (single photon avalanche diode).
 - 2) Brominated flame retardants
Specific brominated flame retardants such as the PBB and PBDE are not used in this device at all.
 - 3) This product shall not contain the following materials.
Also, the following materials shall not be used in the production process for this product.
Materials for ODS : CFCs, Halon, Carbon tetrachloride, 1,1,1-Trichloroethane (Methylchloroform)
 - 4) Compliance with each regulation
 - 4.1) This product complies with EU RoHS Directive (2011/65/EU) and Commission Delegated Directive (EU)2015/863)
 - 4.2) Content of six substances specified in Management Methods for Control of Pollution Caused by Electronic Information Products Regulation (Chinese : 电子信息产品污染控制管理办法).

Marking Styles for the Names and Contents of the Hazardous Substances

Category	Hazardous Substances					
	Lead (Pb)	Mercury (Hg)	Cadmium (Cd)	Hexavalent chromium (Cr ⁶⁺)	Polybrominated biphenyls (PBB)	Polybrominated diphenyl ethers (PBDE)
Time of flight sensor	○	○	○	○	○	○

This table is prepared in accordance with the provisions of SJ/T 11364.

○ : Indicates that said hazardous substance contained in all of the homogeneous materials for this part is below the limit requirement of GB/T 26572

- 5) Country of origin : China
- 6) Product mass : Approx . 0.028g
- 7) The moisture absorption level of this product is MSL.3.
- 8) Taping specifications : Refer to the attached sheet, Page 13 to 15.
- 9) Taping moisture-proof packing: Refer to the attached sheet, Page 16 to 18.
- 10) Eye Safety Considerations

GP2AP02VT00F contains a laser emitter and corresponding drive circuitry. The laser output is Class 1 laser safety under all reasonably foreseeable including single faults in compliance with IEC 60825-1:2014. The laser output will remain within Class 1 limits as long as the Sharp recommended device settings are used and the operating conditions specified in this datasheet are respected. The laser output power must not be increased by any means and no optics should be used with the intention of focusing the laser beam. List of controls, adjustments and procedures for operation and maintenance, including the warning " Caution - Use of controls or adjustments or performance of procedures other than those specified herein may result in hazardous radiation exposure" (or alternatively, equivalent appropriate warnings).



7. Notes

1) Notes concerning receiver surface

Please note enough that it is likely to malfunction when a surface is dirty with garbage and dust, etc.

Moreover, please do not touch a surface.

2) Please take proper methods to prevent ESD. The IC built in GP2AP02VT00F is ESD-sensitive because it is fabricated by sub-micron CMOS process. For example, in handling GP2AP02VT00F, human body and soldering iron etc. should be grounded.

3) Before the circuit design

In circuit designing, make allowance for the degradation of the laser output that results from long continuous operation.

4) Notes ambient light

When set to avoid malfunctions due to a strong disturbance light, such an arrangement to receive ambient light directly on the detector, please be avoided. Also by placing this product in close to other components, it may be a malfunction with the light reflected from their product, structural arrangement to reduce the amount of light receiving surface of the outer, please consider.

5) After being mounted and soldered, if GP2AP02VT00F is deformed by external force or impact, e.g. something falls onto the device, it may result in defective implementation such as lift-off of the terminals. Careful handling should be taken.

6) For soldering : Refer to Page 12.

7) Recommended external circuit

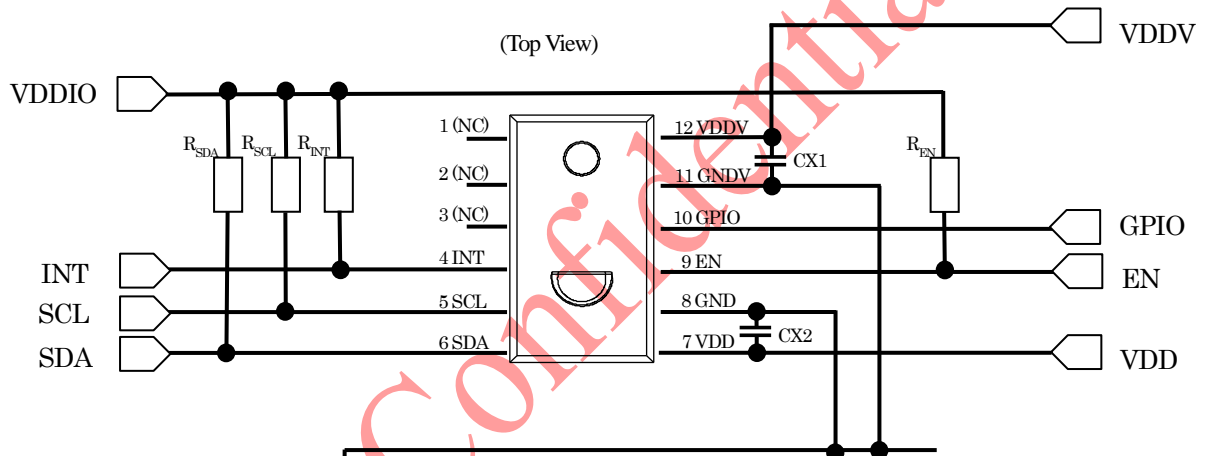

Components	Recommended values
CX1	4.7 μ F
CX2	100nF
R _{SDA} *1	1~10k Ω
R _{SCL} *1	1~10k Ω
R _{INT}	47k Ω
R _{EN}	47k Ω

There are cases to generate a noise because VCSEL driving current flows VDDV terminal, and to distort a waveform of VCSEL driving current.

To reduce these influences, please arrange CX1 within 5mm from VDDV terminal, and wire between VDDV terminal, CX1 and GND terminal as close as possible. Also, the wiring of VDDV is separated from VDD and VDDIO terminals, and the power source of VDDV is separated from VDD is recommended.

And in order to reduce the influence of the power supply noise, please arrange CX2 within 5mm from VDD terminal.

Please evaluate with the actual electrical implementation, and carefully make sure that there is no problem.

SDA and GPIO terminal is NMOS open-drain output and digital input. EN and SCL terminals are digital input.

INT terminal is NMOS open-drain output.

*1 The pull-up resistor needs to be adjusted by communication speed, board capacitance, power supply voltage.

8) Block diagram

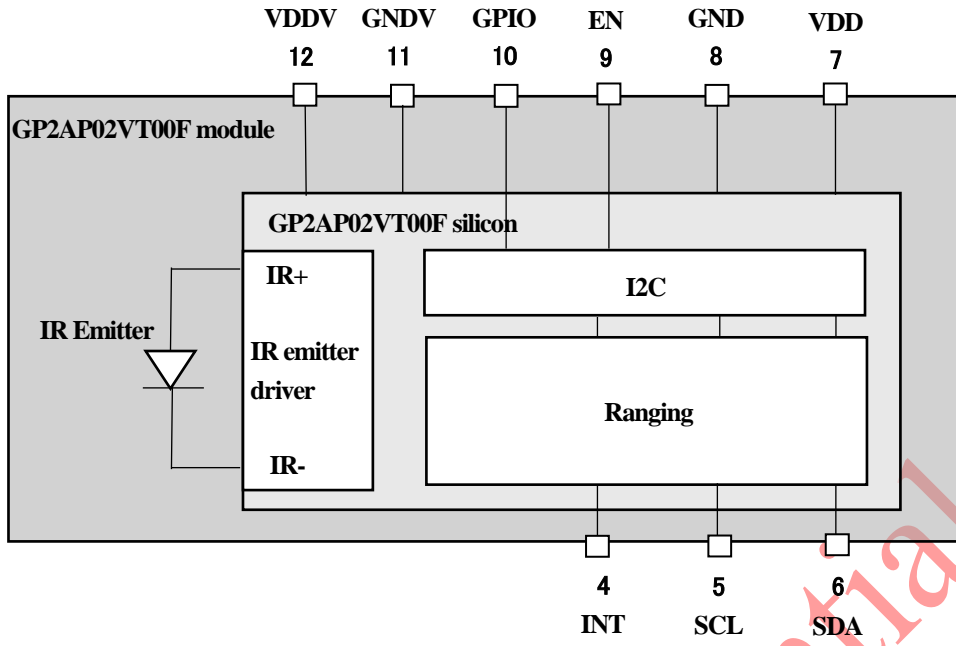

Sharp Confidential

9) Foot pattern of PCB

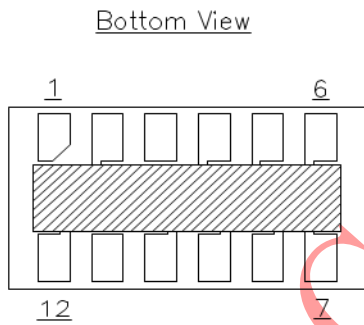
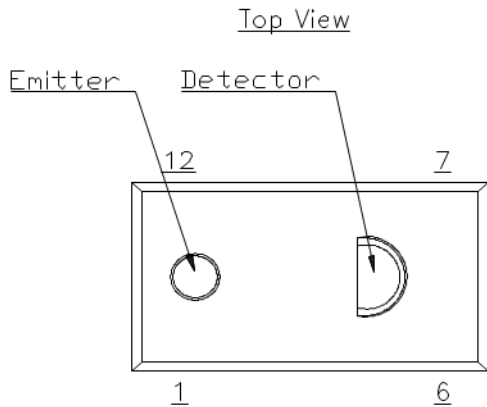

Pin Description

Pin No.	Pin Name
1	(NC)
2	(NC)
3	(NC)
4	INT
5	SCL
6	SDA
7	VDD
8	GND
9	EN
10	GPIO
11	GND V
12	VDD V

Recommended PCB PAD Layout

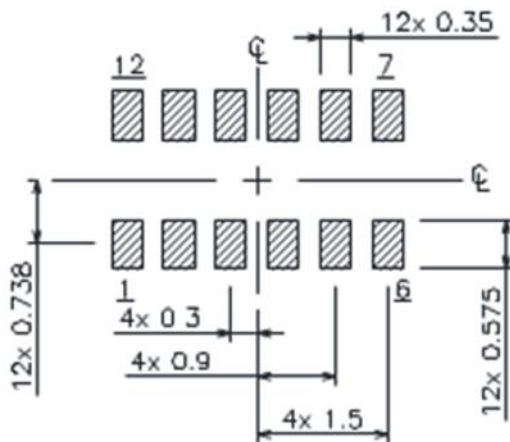

Unit : mm

* Unit : mm

** area Au plating

10) Pin Description

Pin Name	Functional description	Equivalent Internal Circuit
VDD	Power Supply	
VDDV	VCSEL Power Supply	
GND GNDV	Ground VCSEL Ground	
SDA	I2C serial data line The terminal is pulled-up to VDDIO	
SCL	I2C serial clock line The terminal is pulled-up to VDDIO	
INT	Interrupt pin The terminal is pulled-up to VDDIO Open drain output terminal	
EN	Enable pin The terminal is pulled-up to VDDIO	
GPIO	GPIO pin	

*ESD protection device
External circuit

2. Outline Dimensions

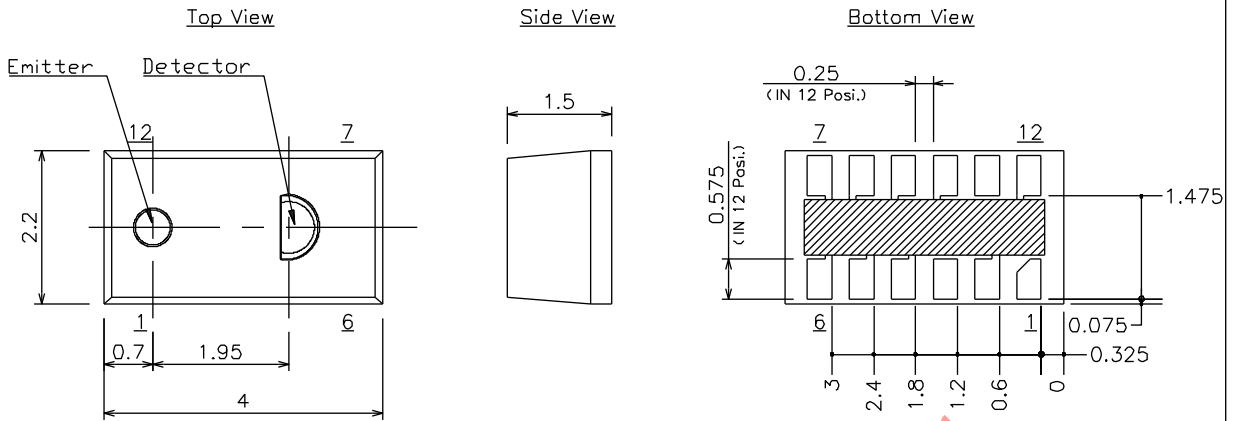

Unit : mm

(Note)

- (1) area : Au plating
- (2) Unspecified tolerance shall be ±0.1mm

Pin Description

Pin No.	Pin Name
1	(NC)
2	(NC)
3	(NC)
4	INT
5	SCL
6	SDA
7	VDD
8	GND
9	EN
10	GPIO
11	GND V
12	VDD V

: Model Number
GP2AP02VT00F = 2 0

: Year
* it repeats the cycle during 21 years except G , I , O , Q , Y

Year	Mark
2018	K
2019	L
2020	M
2021	N
...	...
2032	B
2033	C

: Month (1 to 9 , X to Z)
* X to Z = 10 to 12

: Day (1 to 9 , A to Z)
* A to Z = 10 to 31

: Day Lot Number (1 to 9 , A to Z)
* A to Z = 10 to 31

Charts of the Days / Daily Lot Numbers

10	11	12	13	14	15
A	B	C	D	E	F
16	17	18	19	20	21
G	H	J	K	L	N
22	23	24	25	26	27
P	Q	R	S	T	U
28	29	30	31		
V	X	Y	Z		

Except I , M , O , W

SCALE	MATERIAL	FINISH	Name	GP2AP02VT00F Outline Dimension																
10/1	Terminal: Cu Package : Epoxy	Terminal: Ni, Au	DRAWING No.	C	Y	1	5	4	8	8	i	0	2							
UNIT				1 = 1/1 mm																

3. Ratings and Characteristics

3.1 Absolute Maximum Ratings

Parameter	Symbol	Rating	Unit	Remarks
Power supply voltage	VDD	-0.5 to 3.6	V	
VCSEL voltage	VDDV	-0.5 to 3.6	V	
I2C voltage	VDDIO	-0.5 to 3.6	V	
Operating temperature	Topr	-20 to 70	°C	
Storage temperature	Tstg	-40 to 85	°C	
Soldering temperature	Tsol	250	°C	peak temperature duration:10s

3.2 Recommended Operating Conditions

Parameter	Symbol	Operating condition	Unit	Remarks
Power supply voltage	VDD	2.6 to 3.5	V	
VCSEL voltage	VDDV	2.6 to 3.5	V	
I2C voltage	VDDIO	1.7 to 3.5	V	
Optimum operating temperature	Topr	-20 to 70	°C	
Functional operating temperature	Tfunc	-20 to 70	°C	
SCL, SDA input low level	VIL	-0.25 to 0.5	V	
SCL, SDA input high level	VIH	1.3 to VDDIO+0.15	V	
GPIO, EN input low level	VILIO	-0.25 to 0.5	V	
GPIO, EN input high level	VIHIO	1.3 to VDDIO+0.15	V	

3.3 Electrical and Optical Characteristics

3.3.1 Electrical Characteristics

Ta=25°C, VDD=VDDV=VDDIO=3.3V

(Unless otherwise specified, the external circuit constants follow the recommended external circuit of page 3.)

Parameter	Symbol	Min.	Typ.	Max.	Unit	Remarks
Current consumption (Short mode)	I _{CC,ps}	—	1.7	—	mA	80 ms cycle
Current consumption (Long mode)	I _{CC,dis}	—	10	—	mA	33 ms cycle
Current consumption (Power Down)	I _{CC,s}	—	—	10	μA	
I2C clock frequency	f	1	—	1000	kHz	
SDA output low level voltage	V _{OL,SDA}	0	—	0.4	V	I _{OL,SDA} =3mA
INT output low level voltage	V _{OL,INT}	0	—	0.4	V	I _{OL,INT} =3mA

3.3.2 VCSEL Characteristics

Ta=25°C, VDD= VDDV=VDDIO =3.3V

(Unless otherwise specified, the external circuit constants follow the recommended external circuit of page 3.)

Parameter	Symbol	Min.	Typ.	Max.	Unit	Remarks
VCSEL peak wavelength	λ _{p,ps}	—	940	—	nm	
VCSEL peak current	I _{vcselep}	—	31	—	mA	Short mode
VCSEL peak current	I _{vcseled}	—	64	—	mA	Long mode
VCSEL FOV	Fov	—	25	—	°	

3.3.3 Ranging Characteristics

Ta=25°C, VDD=VDDV=VDDIO=3.3V

(Unless otherwise specified, the external circuit constants follow the recommended external circuit of page 3.)

Parameter	Symbol	Min.	Typ.	Max.	Unit	Remarks
Range distance (Short mode : 100mm)	Rinw1	-10	—	+10	mm	IF=31mA, White 88%
Repeatability (Short mode : 100mm)	Rinrepw1	0	—	+10	mm	Indoor : no infrared
Range distance (Long mode : 100mm)	Rinw1	-10	—	+10	mm	IF=64mA, White 88%
Repeatability (Long mode : 100mm)	Rinrepw1	0	—	+10	mm	Indoor : no infrared
Range distance (Long mode : 1200mm)	Ring2	-4	—	+4	%	IF=64mA, White 88%
Repeatability (Long mode : 1200mm)	Rinrep2	0	—	+25	mm	Indoor : no infrared
Range distance (Long mode : 700mm)	Ring3	-5	—	+5	%	IF=64mA, Gray 17%
Repeatability (Long mode : 700mm)	Rinrep3	0	—	+25	mm	Indoor : no infrared
Range distance (Outdoor, Long mode : 700mm)	Routw	-10	—	+10	%	White 88%
Repeatability (Outdoor, Long mode : 700mm)	Routw	0	—	+25	mm	Equivalent to 50kLux daylight
Ranging speed	Trange	—	33	—	msec	400kHz, Normal mode
Min ranging distance (Short mode)	Rinsmin			50	mm	IF=31mA, White 88%
Min ranging distance (Long mode)	Rinlmin			100	mm	IF=64mA, White 88%
Max ranging distance (Long mode, gray card)	Ringmax	120	—	—	cm	IF=64mA, Gray 17%
Mode changing to Short mode	Shorth	—	80	—	mm	
Mode changing to Long mode	Longth	—	100	—	mm	

※ Repeatability : max – min (10 times evaluation)

3.3.4 Ranging offset error

(Unless otherwise specified, the external circuit constants follow the recommended external circuit of page 3.)

Parameter	Symbol	Min.	Typ.	Max.	Unit	Remarks
Voltage drift	Vdrift	—	—	10	mm	Ta=25°C, VDD=VDDV=VDDIO =3.2~3.4V
Temperature drift (Range Average)	Tdrift	—	—	15	mm	Ta=-10°C~+60°C, VDD=VDDV=VDDIO=3.3V

4. Reliability

The reliability of products shall satisfy items listed below.

Confidence level : 90%

LTPD : 10 or 20

Test Items	Test Condition	Failure Judgment Criteria	Samples (n) Defective (C)
* Temperature cycling	1 cycle -40°C(30min) to +85°C(30min) 20 cycles test	$I_{CC_VDD} > U_p \times 1.2$	n=22, c=0
*High temp. and high humidity storage	+60°C, 90%RH, 240h	Up: Upper specification limit	n=22, c=0
* High temp. storage	+85°C, 240h	Range accuracy <-10% Range accuracy >+10%	n=22, c=0
*Low temp. storage	-40°C, 240h	Condition: VDD=VDDV=VDDIO	n=22, c=0
Operation life	+25°C, VDD=VDDV=VDDIO=3.6V, 240h	=2.8V, Gray Card 17%, Indoor at 600mm	n=11, c=0
Mechanical shock	1000m/s ² , 6ms 3 times / ±X, ±Y, ±Z direction		n=22, c=0
Variable frequency vibration	200m/s ² 100 to 2000 to 100Hz/ Approx. for 4min 48 min/ X, Y, Z direction		n=22, c=0
Reflow solder heat	250°C, 10s, three times. Temperature profile as shown in page 12.		n=22, c=0

In the test *mark above, the sample to be tested shall be left at normal temperature and humidity for 2h after it is taken out of the chamber. (No dew point)

These test results are sampling examples from a specific lot for reference purpose only, and do not constitute any warranty or assurance in connection with the products.

5. Outgoing inspection

(1) Inspection lot

Inspection shall be carried out per each delivery lot.

(2) Inspection method

A single sampling plan, normal inspection level II based on ISO 2859 shall be adopted.

Parameter	Inspection items and test method		AQL(%)
Major defect	1. Disconnection, short		0.1
	2. Electrical characteristics defect in parameter 3.3		
Minor defect	Appearance defect		0.25
	Parameter	Judgment criteria	
	Cracks, Chipping, Scratches, Stains, Burrs	One which affects the characteristics of Parameter 3.3 shall be defect.	

Sharp Confidential

Precautions for Soldering

(1) In case of solder reflow

Reflow is allowed only three at the temperature and the time within the temperature profile as shown in the figure below.

This Profile temperature is the sensor surface package temperature.

Reflow interval shall be within 7 days under conditions, 10 to 30°C, 70%RH or less.

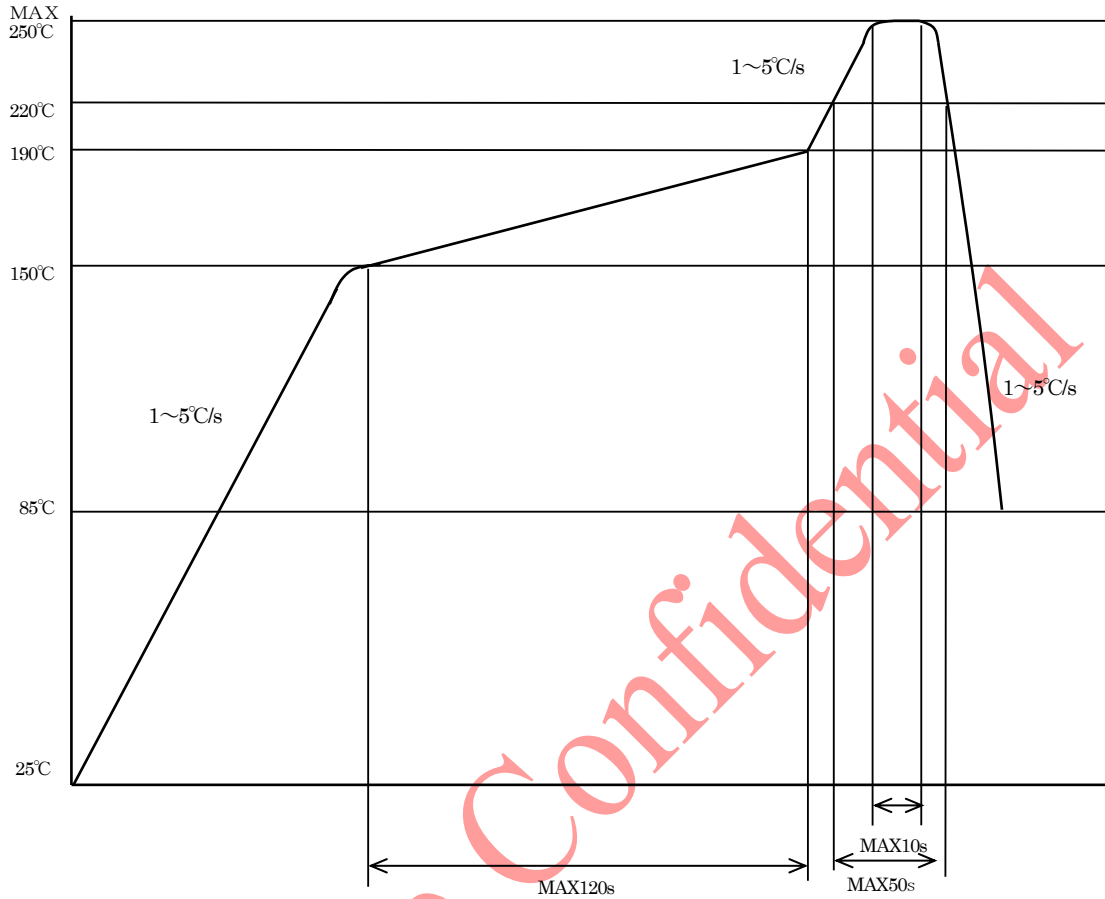

(2) Other precautions

An infrared lamp used to heat up for soldering may cause a localized temperature rise in the resin of package inside.

Even if within the temperature profile above, there is the possibility that the gold wire in package is broken.

Please use after confirmation the conditions fully actual solder reflow machine.

Taping specifications

1. Application

This packing specification sheets specify the taping specifications for GP2AP02VT00F.

2. Taping method

2.1. Tape structure and Dimensions (Refer to page 14.)

The tape shall have a structure in which a cover tape is sealed pressed on the carrier tape of conductive Polycarbonate.

2.2. Reel structure and Dimensions (Refer to page 15.)

The taping reel shall be conductive plastic with its dimensions as shown in the attached drawing.

2.3. Direction of product insertion (Refer to page 15.)

The sensor direction in carrier tape shall be; the detector of the sensor locates to the feeding hole side of the carrier tape and the sensor window faces to the top of the pocket of the carrier tape.

2.4. The way to repair taped failure devices

The way to repair taped failure devices cut a bottom of carrier tape with a cutter, and after replacing to good devices, the cutting portion shall be sealed with adhesive tape.

3. Adhesiveness of cover tape

The exfoliation force between carrier tape cover tape shall be 0.2N to 1.2N for the angle from 160 degrees to 180 degrees.

4. Rolling method and quantity

Wind the tape back on the reel so that the cover tape will be outside the tape. Attach 16cm or more of blank tape to the trailer and 40cm or more of blank tape to the leader and fix the both ends with adhesive tape. One reel shall contain 2,000pcs. Except for the case that device is removed. There must not be continuously two or more Stock-Outs.

5. Safety protection during shipping

There shall be no deformation of component or degradation of electrical characteristics due to shipping.

6. Surface resistivity

Name	Surface resistivity (Ω/\square)	Material
Carrier tape	1×10^4 to 1×10^8	Electroconductive polycarbonate
Cover tape	1×10^4 to 1×10^7	Poly ethylene terephthalate
Reel	Less than 1×10^9	Poly phenylene ether

7. Tape and Real structures

7.1 Tape structure and Dimensions

Tape outline drawing

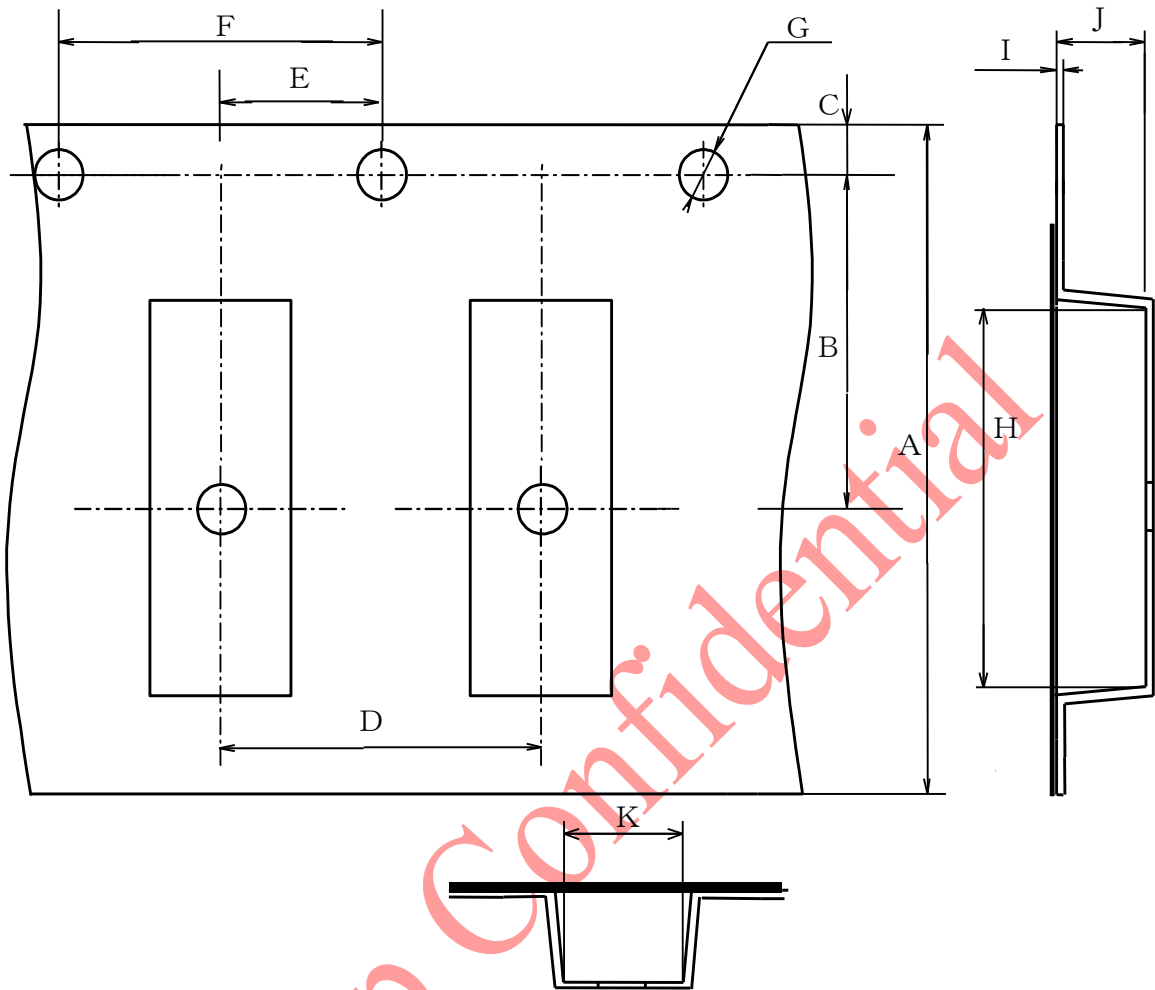

Symbol	A	B	C	D	E	F
Unit	±0.1	±0.05	±0.1	±0.1	±0.05	±0.1
mm	12.0	5.5	1.75	4.0	2.0	4.0

Symbol	G	H	I	J	K
Unit	+0.1 -0	±0.1	±0.05	±0.1	±0.1
mm	Φ1.5	4.25	0.28	1.75	2.45

7-2. Reel structure and Dimensions

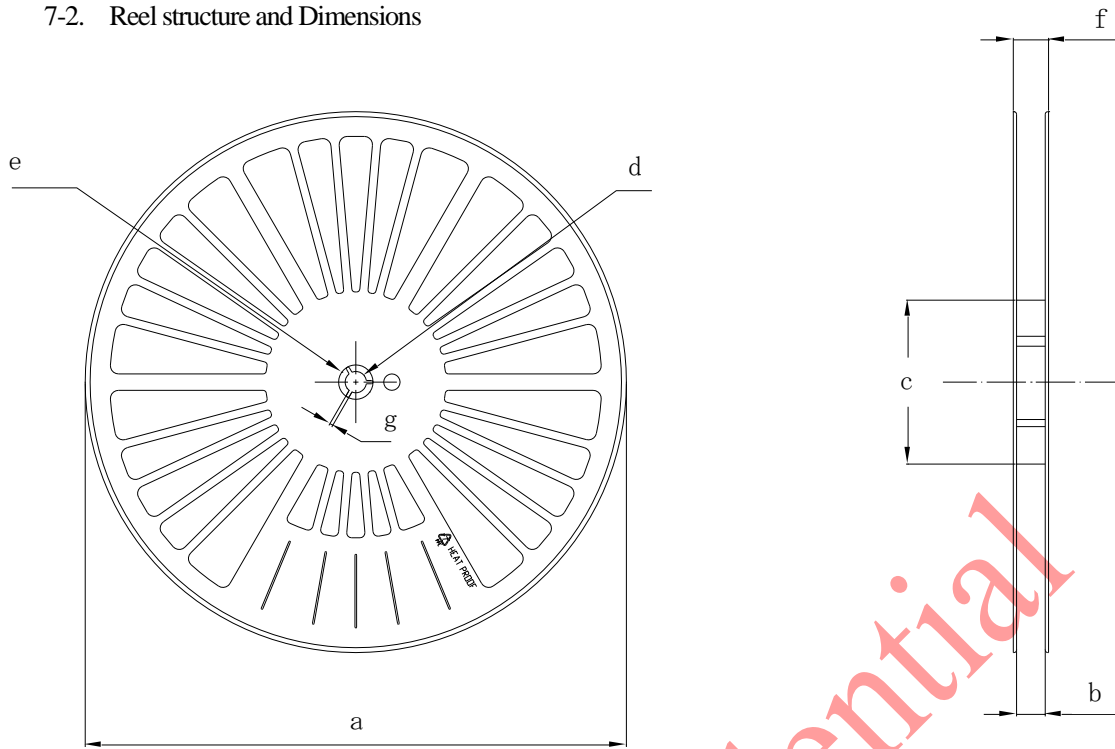

Symbol Unit	Check word						
	a	b	c	d	e	f	g
mm	$\phi 180 \pm 2.0$	13.5 ± 1.0	$\phi 60 \pm 1.0$	$\phi 13 \pm 0.2$	$\phi 21 \pm 0.8$	17.1 ± 1.0	2 ± 0.5

7-3. Direction of product insertion

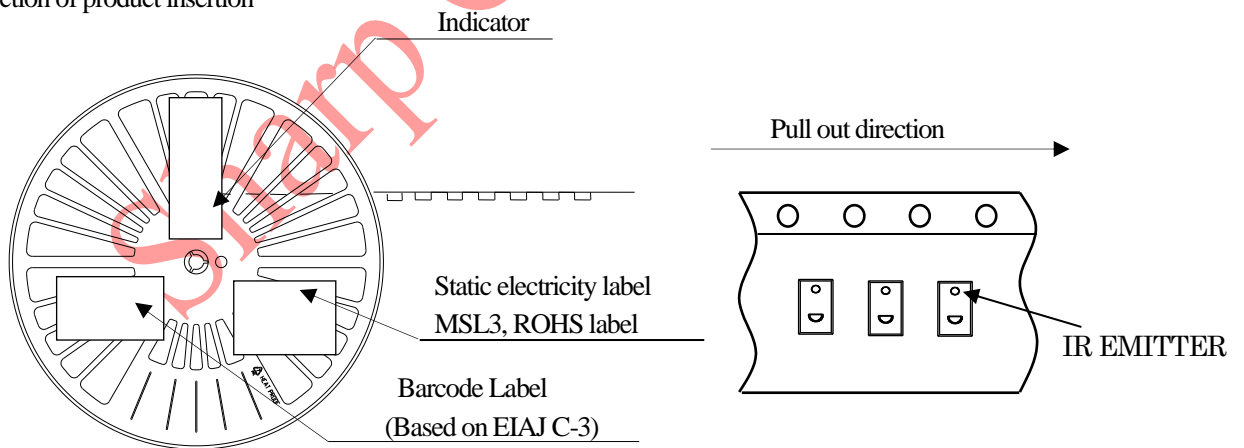

Taping moisture-proof packing

1. Application

This packing specification sheets apply to the moist-proof packing for the GP2AP02VT00F in the taping package.

2. Packaging specifications

2.1 Packaging material

Name	Material	Counter measure for ESD	Quantity
Aluminum laminate bag	Aluminum polyethylene	Conductive type	Refer to 2.2
Label	Paper(-made)	Non	
Siccative	-	Non	
Packing case	Paper	Non	
Cushioning material	Urethane	Non	
Indicator	Paper	Non	

2.2 Packaging method

- (1) Fill necessary information to barcode labels.
- (2) Paste one of the barcode labels and a moisture indicator to a tape reel (contains 2,000 devices per reel).
- (3) Seal the aluminum laminated bag that contains the tape reel and siccative, and paste one of the barcode labels.
- (4) Pack 5 aluminum laminated bags (contains 1 reel each) into the designated packing case, where Urethane cushioning material are placed on the top of the packing case.

Package shape	Product	Quantity	Moisture-proof sack Quantity
Tape reel (φ 180mm)	1 model	2000pcs. / reel *	1 reel / laminated bag

- (5) The packing case would be then sealed with the craft tape, with barcode label (based on EIAJ C-3).
(Total of 10,000pcs. per carton) * Except for the case that device is removed.

3. Storage and Treatment after Unsealed

3.1 Storage conditions The delivered product should be stored with the conditions shown below;

Storage temperature : 10 to 30°C

Humidity : below 70%RH

The warranty term for the shipped product shall be for 1 year after shipping to the designated place by the ordered customer.

3.2 Treatment after open

- (1) After unsealed, devices should be mounted under the temperature condition of 10 to 30°C, at the humidity condition of below 70%RH, within 7days.
- (2) In case that long term storage is needed, devices should either be stored in dry box, or re-sealed to moist-proof bag with siccative and leave them in the environment where the temperature is 10 to 30°C, at the humidity condition of below 70%RH. Devices must be mounted within 2 weeks.

3.3 Baking before mounting

In the event that the devices are not maintained in the storage conditions described above, or the enclosed siccative indicator already turned its color to light-green, baking must be applied before devices are to be mounted.

The case that Devices were not mounted under the temperature condition of 10 to 30°C at the humidity condition of below 70%RH or lower within 7days, Baking process must be applied before devices are to be mounted.:

Please also note that baking should only be applied twice.

Recommended condition : ①100 to 110°C, 12 to 24 hours ②125°C, 6 to 24hours

※ Baking will not properly done in packing condition.

To complete the baking properly, devices should be placed to the metal tray.

Recommended condition of reel baking :125°C, 6 to 24hours

※ In the case of reel baking, hung the reel in the oven by passing the shaft in the center hole of reel.

Please avoid laying the reel.

3.4 Placement of reels in an oven

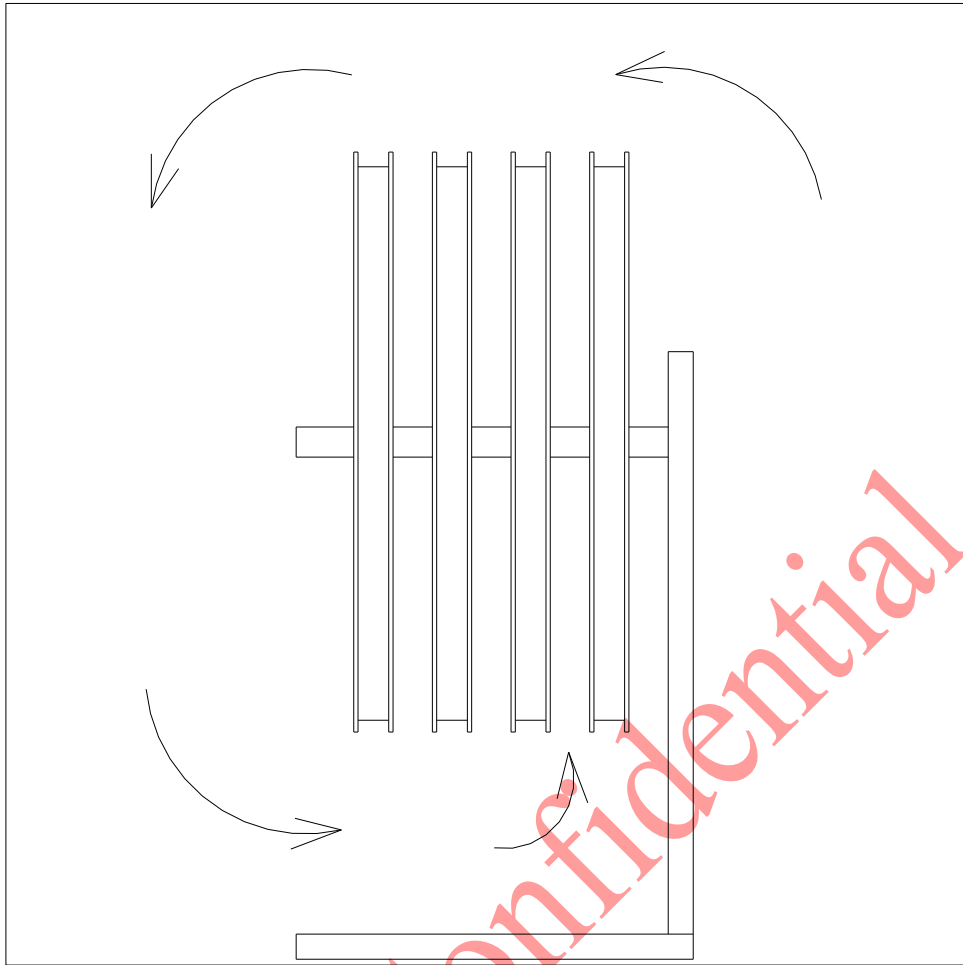

- 1) Please hang reels by using a center hole for fixing the reel.
Please keep some space between reels for better air rotation in the oven.
Please do not lay a reel down in the oven to avoid any damages for the tape edge and the flange of reel.
- 2) Please make sure the carrier tape does not have any slack in a reel before baking to avoid peeling the cover tape off.
Since the tape using for fixing carrier tape is not heatproof, there is a case to remain glue.
So if necessary, please change the tape to a heatproof one.

4.Packing

Inner Packing

① Inner Packaging drawing

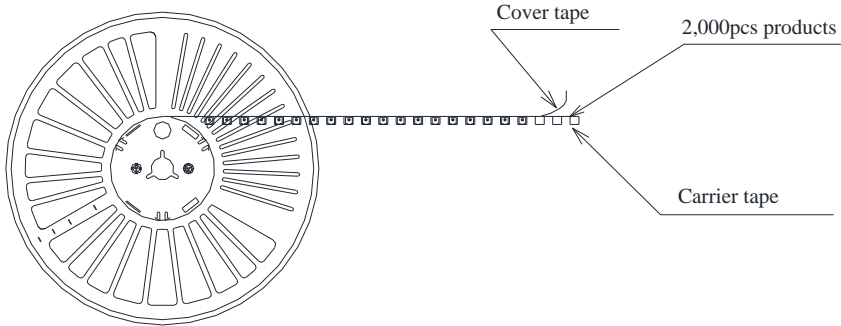

- ② Inner packing material : • Reel(PPE) • Carrier tape (PC) • Cover tape(PET)
- ③ Quantity : 2,000pcs./Reel

Outer Packaging

① Outer Packaging drawing

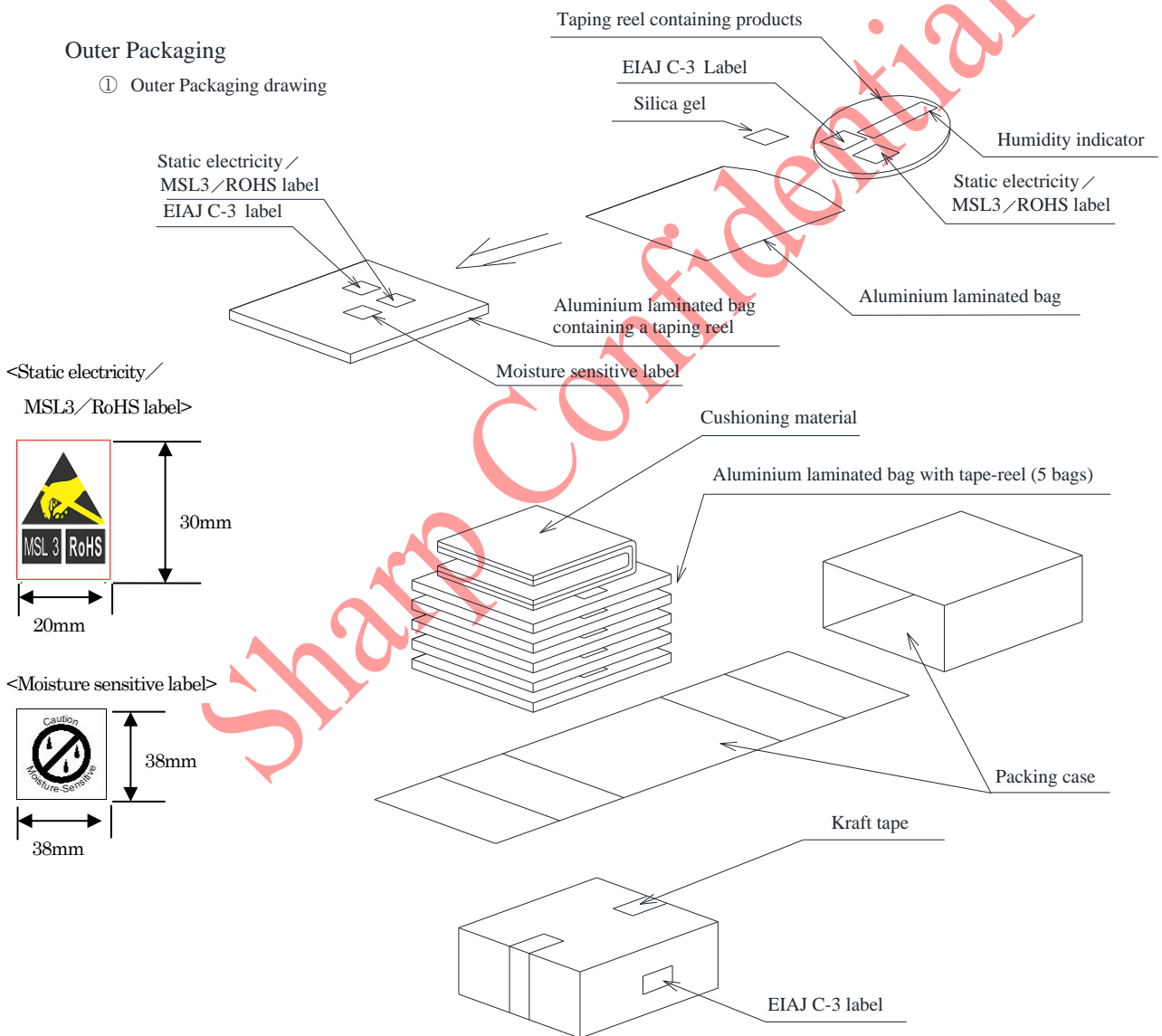

- ② Outer packing material: Packing case(Corrugated cardboard), Cushioning material (Urethane)
Aluminium laminated bag (Alumi-Polyethylene)
Humidity indicator card (paper), Label(paper), Silica gel, Craft tape
- ③ Quantity: 10,000pcs./box
- ④ The contents of the carton indication conforms to EIAJ C-3 and the following items are indicated.
Model No., Internal production control name, Quantity, Packing date, Corporate name, Country of origin
- ⑤ Regular packaged mass: Approximately ' 800g

8. Revision History

Revision	Description	Date
0.0	Preliminary release	12-Jan-2018
0.1	Change of electrical characteristics	30-Apr-2018
0.2	Change the pull-up register.(R _{SDA} , R _{SCL})	30-May-2018
0.3	P3 - GPIO terminal delete pull-up resistor	28-June-2018
	P6 - 10) Pin description GPIO terminal	28-June-2018
	P8-9) VDD condition	28-June-2018
0.4	3.3 Electrical and Optical Characteristic	12-July-2018
0.5	P2 Eye Safety Considerations	2-Aug-2018
0.6	3.3 Electrical and Optical Characteristic (outdoor)	7-Aug-2018
0.7	P3,5,7 Outline dimensions P.2 EU RoHS Comments, Product mass P.14 Tape outline drawing P.18 Regular package mass	22-Jan-2019
0.8	3. Ratings and Characteristics	1-Feb-2019
0.9	3. Ratings and Characteristics 7. Tape and Real structures	15-April-2019
1.0	3. Ratings and Characteristics 4. Packing	25-July-2019
1.1	All. "Confidential" etc. delete 4. Packing "Huawei" delete	26-Aug-2019
1.2	2. Outline Dimensions 7. Notes	22-Nov-2019
1.3	2. Outline Dimensions 3. Ratings and Characteristics 7. Notes Taping specifications 7. Tape and Real structures	25-Nov-2019